

## Tennessee T's



## Model T Ford Club

Editor- [Bill Robinson](#)

Be sure to visit our club's website

<http://tennesseets.weebly.com/>

Greetings Model T'ers

It's hard to believe we have been talking about hosting the National Tour for almost two years now and it's finally here. In just a couple of short weeks we will travel to Cookeville, TN for the Model T Ford Club of America Highland Rim National Tour, hosted by the Tennessee T's. Again, I would like to give a big shout out and thank you to George and Ramona Akin and all the many Tennessee T volunteers that have worked really hard putting this tour together. There is a lot of work that many of you will be giving your time to help make this tour a success. I knew you would rise to the occasion. I for one have never been to a national tour and I am really looking forward to seeing close to 150 cars and meeting all the new people. As I have said before, this is our chance to show the rest of the Model T world what the great state of Tennessee is really like. We have great roads and great stops planned, and as always good food to eat. Model T's always get a lot of attention where ever we go. I'm sure the people of Cookeville and the surrounding area will also enjoy seeing all the cars and meeting each of you with a lot of questions, so have a good time and most of all be safe. This is our time to show what a good group the Tennessee T's really are. Thank you all.

Being the president of the club, I hear from a lot of Model T people and others who are curious about our club. A lot of people don't even have a car but because of some Model T person that has introduced them to the world of Model T's they want to find out more. Most "google" Model T's in our area and that brings them to our Website and our newsletter. Most every week I hear from someone asking about our club. Most of them tell me how good of a job I do with the news letter and the Website. I am quick to set them straight and tell them that's not my job. I have a lot of people tell me we have the best news letter around. Having been in a lot of clubs in my life there is not much harder of a job than putting together a quality news letter. Again, I want to say thank you to Bill Robinson for all the work he puts into the news letter and the website. Month after month we have a really good news letter. I always look forward to when it's about that time for it to come out. Bill can always use your help. There are many places in the news letter for your input. If you have a Model T story, an experience, or maybe you want to recognize a member or a particular car, sit down and write up a short story to share with the rest of us. Send it in, we always need information for the news letter.

A Model T club is nothing without its members and most of all the cars and places to drive them. Please share with me any ideas for a tour you would like to do. Please help us in hosting a tour. You might think you don't know how to route cars. I am always willing to help. This past weekend one of our kids took us to a really unique restaurant in the middle of nowhere. My first thought was "Model T Tour". Give me your Ideas and we will see if we can plan a tour around them.

Thank you everyone for your participation,

Happy T'ing

Ricky

A Message From Ricky Williams,  
Our President



# Club Officers 2018

**President-** Ricky Williams  
Humboldt, TN  
731.618.0207  
[rwilliams@click1.net](mailto:rwilliams@click1.net)



**Vice President-** Dennis Plank  
Humboldt, TN  
731.616.6609  
[daplank@bellsouth.net](mailto:daplank@bellsouth.net)



**Secretary-** Vandy Williams  
Humboldt, TN  
731.414.9085  
[vandy1311@yahoo.com](mailto:vandy1311@yahoo.com)



**Treasurer-** Connie Plank  
Humboldt, TN  
731.313.1496  
[csplank@bellsouth.net](mailto:csplank@bellsouth.net)



**Chaplain-** Mac Flowers  
Waverly, TN  
931.535.2327  
no email



INDEX	
Presidents Page	Pg 1
Secretary's Report	Pg 3
Highland Rim Tour Notes	Pg 3
Tours and Events	Pg 12
Hey Bill!	Pg 4
Ford Fix and Facts	Pg 5
The Rodeo Truck	Pg 6
The Journey Continues	Pg 7
A New Manifold Cooker	Pg 10
Linda Moorehead Recipe	Pg 11
Model T Traveler	Pg 12
Misc	Pg 14 & 15

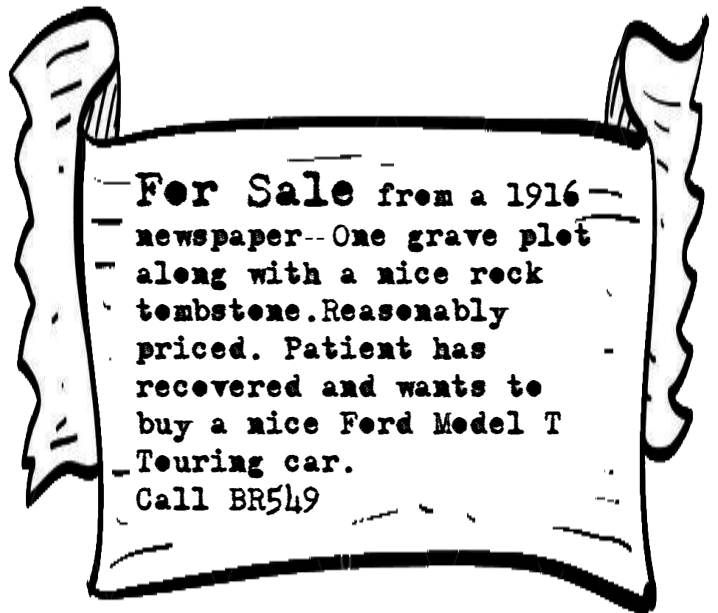

It's here- in just a few days!

**MTFCA National Tour #2**  
Highland Rim Tour  
Cookeville, TN August 17-22 2019  
Hosted by the Tennessee T's



It is less than two weeks before the tour and we are expecting about 140 Model Ts in Cookeville. If you are not touring with us feel free to visit us while in Cookeville.  
George

Registration is now closed. Our volunteers are greatly appreciated. For questions contact:  
George Akin [hora7@aol.com](mailto:hora7@aol.com)

*The Money Bucket* as of 7.30.2019  
submitted by Connie Plank,  
club treasurer

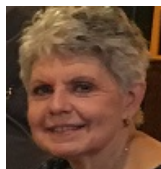

**Club's Regular Account**

<b>Starting Balance 05/31/19)</b>	<b>\$3,625.53</b>
Total Deposits	\$15.00
Total Deductions	\$0.00
<b>Ending Balance (07/31/19)</b>	<b>\$3,640.53</b>

**Nat'l Tour Checking Account**

<b>Starting Balance (05/31/19)</b>	<b>\$45,736.99</b>
Total Deposits	\$2,860.00
Total Deductions ***	<b>-\$6,559.01</b>
<b>Ending Balance (07/31/19)</b>	<b>\$42,037.98</b>

Deductions

Walmart - Centerpieces (Banquet)	\$186.29
Vinnie T's Catering – Deposit Bar (Banquet)	\$150.00
Office Depot – Booklets (Banquet)	\$832.84
Charlies Brown's Co. - T-shirts; Bags; Magnets	\$5,389.88
<b>Total Deductions **</b>	<b>\$6,559.01</b>

## Highland Rim Tour notes

**Save yourself some time!**

For those reading this, if you are attending the Highland Rim Tour- thoroughly inspect your Model T per the inspection form. Check off all appropriate blanks, then SIGN & date the form.

**Volunteers take note**

----->Volunteers meeting in the lobby of the Country Inn 10 am ~~Friday~~ **Saturday**

A few volunteers are still needed for various jobs at the tour. If interested, see George or Ramona.

The Tennessee T's want to thank George and Ramona for their hard work, dedication, and tremendous amount of time (2 years) they have invested in this tour to make it a success.  
Hoorah!



**The Ocean 2 Ocean Re-Run Tour** (NYC to Seattle) took place June 15- July 14, 2019. Three of our members participated- Mark and Paula Gember, Dom Demio, and Doug Hauge. Folks, this took courage & stamina.

Paula created a video diary of their experiences. Her videos can be viewed on her YouTube site by searching her channel [SweetTing](#).

The videos are also listed and linked through the Tennessee T's website. Click on the [VIDEO CLIPS](#), which will direct you to a listing of her videos



# HEY BILL !!!!!

submitted by Jenni

Hey Bill! Am sending photos of our Blue Ridge Riders Club tour in July. We discovered a 1920s Log Cabin Motor Court, complete with historical designation, on Hwy 25N between North Asheville and Weaverville, NC! What a HOOT! I am sending photos from my cell phone. This was the first BRR tour in several years...and it's only the beginning!! See you in Cookeville we hope!

...Ken Nye and Jenni Whitehall-Tennessee T's member, Max Larson also attended.



Here's the website of our motel. Quite a history...a step back into the days of Model T road travel!!! <https://www.theashevillescabins.com/>



# FORD FIX AND FACTS

Herm Gierow

The Model T engine and transmission assembly is a cumbersome piece of machinery to handle and is inconvenient to store. I have built a small engine stand modeled after the originals which makes both a convenient storage rack and an assemble bench. Since the stand loads the crankcase in the same manner as it is when installed in the car, there is not any unusual stress imposed upon the unit. All construction is of wood and parts are cut from 2 x 4's and are assembled with glue and nails. In making the front mount it is advisable to first drill a hole a little larger than 1 1/2 inches in a short length of 2 x 4 and to then saw through the hole to form the mounting surface. The block should then be sawed to the correct length as indicated in the drawing.

For those individuals who did not get a chance to view the Dunnivant's Mall Show, Dan Shady has built an excellent stand from channel iron for a Model A engine.

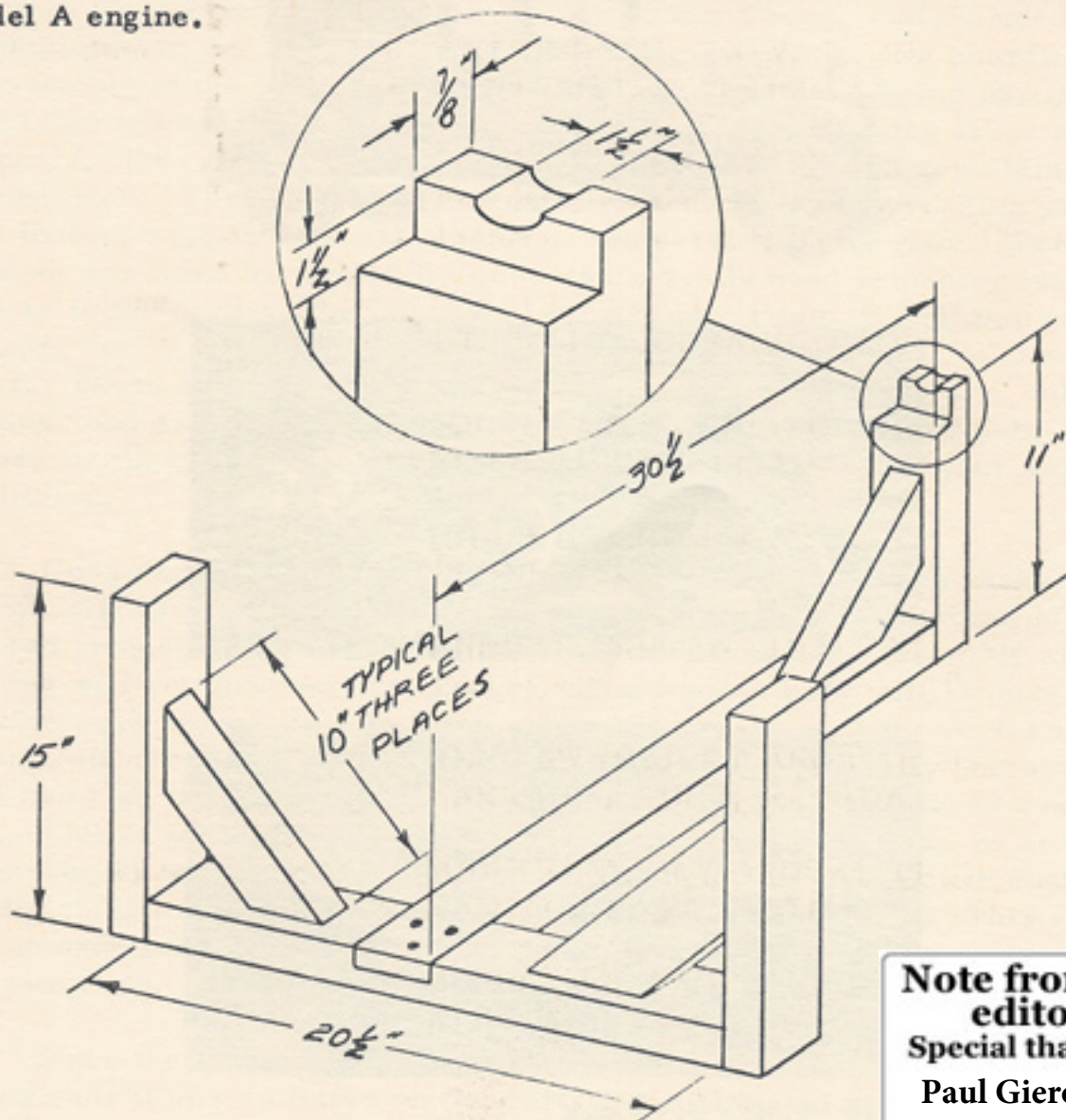

**Note from the editor:**  
Special thanks to  
Paul Gierow  
(son of Herm)  
for submitting this  
article

This article was originally published in the AUTO ANTIQUARIAN NEWS, North Alabama Region A.A.C.A. May 1967



## The Rodeo Truck

**New Members Phillip and Mary Lee** joined our club in the Fall of 2018. Then they attended the 2019 Model T Reunion in Richmond, IN this Summer. The MTFCA asked if they could feature them and their 1927 Model T Roadster in the upcoming *Vintage Ford* magazine. *Look for the article in the upcoming issue.*

**The Lees have had their T in several Franklin, TN events including the Williamson Rodeo Parade and the Franklin 4th of July celebration on Main St.**



**The Lees are volunteers at the big Model T Tour in Cookeville, TN.**

**As a sidenote-** Phillip contacted me wanting if anyone in our area ever went on a "small tour". Just so happened that David Walker, Paul Gierow, and myself had a lunch ride planned from Ardmore to Delina Crossroads planned on Wednesday, July 31st. I invited Phillip to come along. That old truck never missed a lick. If it did he never owned up to it. Bill



## THE JOURNEY CONTINUES...by Paula Gember

For Theton Ogle, participant in the 2019 O2O Rerun, the adventure began well after arriving at the terminus in Seattle. Owner of TinSnips Metal Fabrication in Winchester, Virginia, Theton does intricate metal fabrication and restoration for virtually anything metal. But when it comes to Model T's, he's somewhat of an oddity. He bought his 1917 Touring on an impulse (see my Day 2 O2O video to learn more), but is not a mechanic. He had never been on a tour before, and knew very little about Model T's. When he heard about the O2O Rerun he quickly signed up. With the help of friends Greg Stewart and Neil Kiracofe, he had the ultimate support system. Three weeks before the trip, the car was still just a body on jack stands, but under Greg's tutelage, they soon had it ready for the long journey ahead. Neil hauled "Ernie" to New York in a trailer, or more appropriately, 'mobile garage' the threesome had outfitted with everything imaginable.



Thanks to  
Paula  
Gember for  
submitting  
this article

They travelled cross country with the Hauge clan. Neil followed with his truck and trailer. Initially, Greg did most of the driving and took care of *everything* on the car. Theton eagerly watched, listened, and learned. Part way through the trip, Neil unexpectedly had to return home, so "Ernie" loses his ride back to Virginia. While the rest of us have arranged to ship our cars home, Doug plans to drive his T 'as far as he can' before he has to get back and resume care of his parents in Florida. Theton is excited to continue travelling so the two pair up. They head south through Oregon, drive along the California coast, then turn east through the desert into Nevada.



They mostly stay in state parks and campgrounds. Theton quickly learns how to pitch a tent, start a campfire *without* gasoline, and change a flat tire with the wheel on the car. They enjoy many beautiful sites along the way: the snow capped mountains at 9000 feet, the salty breeze along the coast, the majestic redwoods, and relics of a bygone era.



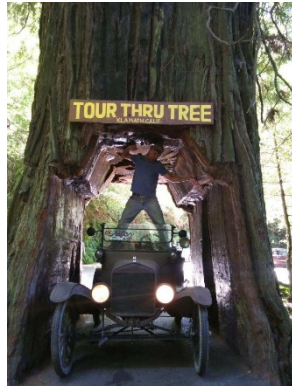

Nine days and ~1550 miles after leaving Seattle, the two of them arrive in Las Vegas. They enjoy some much needed R&R before Doug prepares his car for shipment and catches a flight home.



*This is where Theton's real adventure begins...he's on his own now!*

Leaving Vegas, he travels solo southeast through Arizona and New Mexico, before crossing the panhandle of Texas. He swings north somewhere along the way to drive through Oklahoma (born and raised in nearby Kansas, he said couldn't bypass Okie) He camps in state parks, in church parking lots, even RV parks, drawing crowds of curious onlookers. With his scruffy beard and ragged appearance, many must think he's destitute or homeless and offer him a place to stay, or home cooked meals. He meets up with some motorcyclists camping nearby, and they give him a mascot, he now calls "Bert."



In Mississippi, he meets up with fellow O2O rerun participants Kirk and Wayne. They dine at Jonnie's in Tupelo, sitting in Elvis' booth, then camp together at Davis Lake just off the Natchez Trace Parkway. The next morning after servicing the car, he heads north on the Trace, crossing the river up and back again to pick up Tennessee, then heads towards us in Alabama.



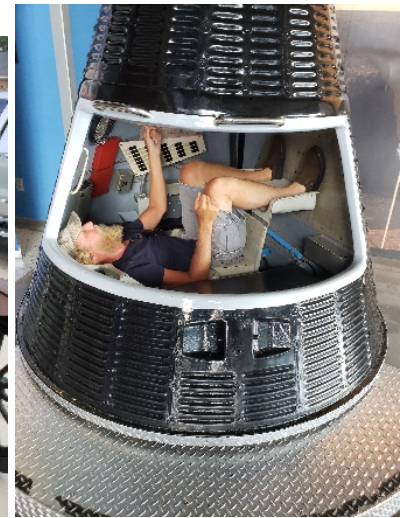

Theton arrives just before heavy storms hit. We enjoy hearing about his travels...he says it is just dumb luck that he has made it this far. He decides to lay out a second day with us to avoid the bad weather brewing to the east, so we visit the Space & Rocket Center. He leaves early the next morning and by nightfall he's camping in Georgia. He then heads on a winding path through SC to NC, camping just outside Asheville.



The route for the 2019 O2O Rerun took us through thirteen states, and those that participated thought that was an impressive accomplishment. Theton has surpassed all of us having hit every state in the South but Florida. He says saving the Sunshine State for another adventure. His mentors Greg Stewart and Doug Hauge are so proud of what he has done on his own. It's awesome!



As I'm putting the closing words on this, I receive a text that Theton is now somewhere in Kentucky. His adventure continues... Go! Theton! Go!



## Our New Manifold Cooker by ElaineVechorik

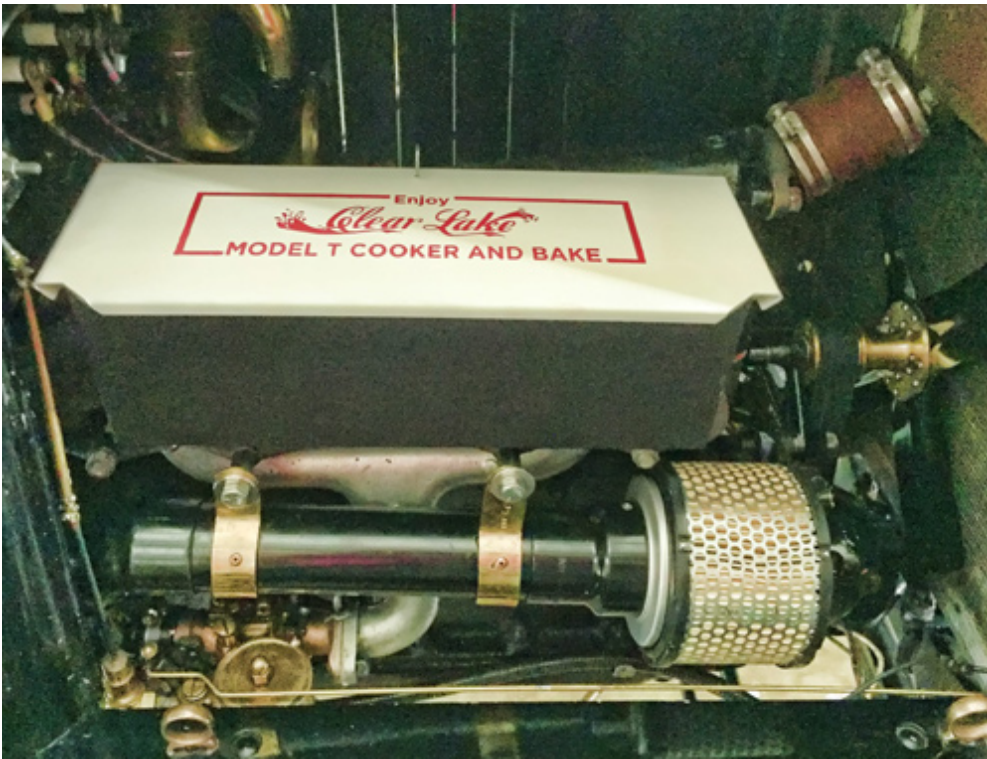

Not everyone in our club is familiar with the function of an **Exhaust Manifold Cooker**. Basically, the unit clamps onto the exhaust manifold, then it gets loaded with food, some water is added to the cooker. Then, the Model T gets driven, which allows the manifold to heat the food until it gets cooked. The particular cooker on the left was recently purchased by **Elaine Vechorik**.

Elaine was disappointed, because when the new cooker arrived, the top lacked the logo like the older units, so, she used her artistic talents and screen-printing experience and applied the above logo to it. She also added the 2 food holding pans to keep the food out of the water. The air filter was made by her husband Vech. He made the filter from parts used on a BMW motorcycle.



Note from the Editor- Special thanks to:  
**Elaine Vechorik**  
for submitting this article

Continue to the next page-  
**Linda Moorehead** has submitted 2 great and easy recipes. This month is a Hot Ham and Swiss Croissant. Watch for the second recipe in the October Newsletter







# HOT HAM & SWISS CROISSANTS (perfect to make ahead)

Another great  
Manifold Cooker  
Recipe,  
Thanks to:  
Linda Moorehead

## Ingredients

- 2 Tablespoons Dijon Mustard
- 1 Tablespoon honey
- 1 Tablespoon brown sugar
- 4 croissants split
- 8 slices swiss cheese
- Pound deli ham any flavor you like and you might not end up using the whole pound, depends on how thick you like your sandwiches

## Instructions

1. Mix the mustard, honey and brown sugar together.
2. Spread the honey mustard mixture on each side of the four split croissants.
3. Place a slice of swiss on each half of the croissants.
4. Top the bottom half of each croissant with however much ham you like.
5. Place two halves back together.
6. Wrap in foil.
7. Place in fridge for later.
8. Place in a Manifold Cooker and ride around.

# Model T Traveler

by Ricky Williams

I got a call from George Akin a few days ago asking if I could help out a fellow Model T'er. Of course, I said I would. He gave me his contact information and I gave him a call. His name was Kenneth.

Kenneth was an interesting fellow. He was traveling from Georgia across country. Along with his two riding companions, a cat and a pet flying squirrel. Traveling in a fully restored 1916 Model T Touring car with a Model T homemade trailer to help carry his stuff.

George told me he needed help with his brakes. Someone had installed new disk brakes on his car and got the brackets on backward, which made the brake pads only contact about 50%. Needless to say his brakes were shot. I ordered him a new set of brake pads and was prepared to reinstall his disk brakes on his arrival.

Thursday afternoon we had been staying in touch and about 4:00 here he comes down the road with a beautifully restored Model T touring car pulling a trailer that weighed 1500 pounds. I told him "Nice Car" and asked him where he got it. Come to find out this car belonged to his dad, who passed away around 6 years ago, and had been sitting in the yard since the early 70's. Kenneth was not a Model T person and after his dad's passing didn't know what to do with the car other than sell it. The car was the last thing left after the estate was sold out, so what to do?

Kenneth and his brother figured the best thing to do was to get it running before they tried to sell it. Knowing nothing about a Model T they started dragging it down the driveway with a tractor to see if they could start it. When they got to the end of the drive they met an older gentleman walking down the road. The gentleman asked him, what are you going to do with that Model T? They told the gentleman they were trying to start it so they could sell it. Then the gentleman told them, you ought to restore that car in memory of your dad. Kenneth said he had never seen this man before but he knew it was a sign from his dad to get the car fixed.

Having never been around a Model T, Kenneth started on a six year journey restoring a rusted out 1916 Model T Touring to perfection. When this thing drove up to my house it had more lights and electronics than my F-450. It was decked out for driving.

Here is where the story really tugged at my heart. Kenneth lost his daughter two years ago. He decided it would be good healing to drive his father's Model T across the country. Destination, Yellow Stone National Park, where he and his daughter were suppose to have met up but never got the chance. Kenneth says he knows his daughter will be in Yellow Stone waiting on him.

A month ago he set off on a three month adventure from Georgia, through the Carolinas' across Tennessee and the Mississippi River headed west. After barely making it through the Appalachian Mountains with a 1500 lb trailer, he stopped off at George's house for a few days, where George changed out his ring gear to give him more power to pull that trailer. By the

time he arrived in West Tennessee he was in need of a brake job. We fixed him up and he left out on Friday headed to Reelfoot Lake and up to Hickman, Kentucky where he crossed the Mississippi river on a ferry. I talked to him today. He had a flat on his trailer and had stopped off at a state park in Missouri for a few days to rest.

Good luck to Kenneth on his Model T adventure. I know of no better way to find peace and healing than to drive across county in a Model T Ford.

Ricky



Special Thanks to

**Ricky  
Williams**

for submitting  
this article



# Condolence

With great sadness, I am letting you know that Marge Krull, wife of Don, passed on July 18, 2019. Marge was from Galesburg, IL and had been a member since 2001.



To view the obituary <https://www.h-p-w.com/notices/MrsMarjorie-Krull>

## READY TO JOIN OUR CLUB ?

[New member application.. see our website](#)

**The Tennessee T's club** is a member of both the MTFCA and the MTFCI. Most of our members are also members of both associations that help preserve our hobby and our historic old cars.



# Tours and Events

Contact Ricky Williams, our club President, if you have a tour or event planned to be sure the date is still open. [rwilliams@click1.com](mailto:rwilliams@click1.com)

Date	Event (Tennessee T's events are <b>bold</b> )
August 17-23, 2019	<b>MTFCA National Tour, Highland Rim Tour hosted by the Tennessee T's</b> , based out of Cookeville, TN
August 30, 31, & Sep 1, 2019	Ohio Jamboree, Heath-Newark, Ohio, details <a href="http://www.nwo-modelt.org/PDF/2019-Jamboree.pdf">http://www.nwo-modelt.org/PDF/2019-Jamboree.pdf</a>
Sept. 4-8, 2019	Salem, Missouri USA - 37th Annual Hillbilly Tour- To register or for info packet contact: Gene Gemmill, 417-881-6702
Sept. 28-Oct. 2, 2019	Park County Indiana Covered Bridge Tour. For info: Brian Jordan at 765-762-6067
October 9-12, 2019	Hershey Swap Meet
December- all month long!	Every town has a Christmas Parade. Put a wreath on your Model T and join the fun

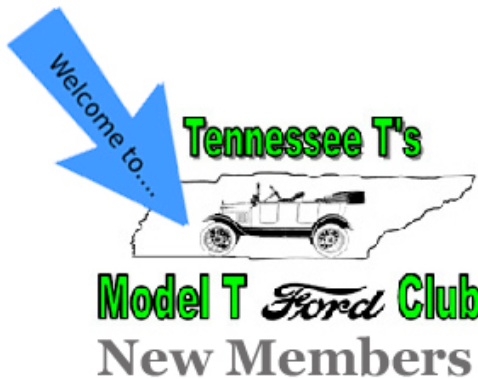

Daniel and Annette Rubino, Marion, KY



## Members on the Mend

**Charlie Owen** had back surgery on Friday, August 2nd. Maybe this operation will get him back behind the wheel of his Model Ts again.



Hey, we tour  
the whole  
dang state!  
And then some!

**Need A  
TENNESSEE T'S  
T-SHIRT?  
Contact Hillary**

[hillary.spratlin@gmail.com](mailto:hillary.spratlin@gmail.com)



## BOOGER.. IN THE PAN!

Find something in your old car that is not supposed to be there? Let us all see your find!

Here's how:

Write a short article and tell our club members about what you found. Send pictures to the editor. [tennesseets@hotmail.com](mailto:tennesseets@hotmail.com)

**FULL TIME COLLEGE STUDENTS  
CAN JOIN DUES - FREE**

Don't forget- Big John makes beautiful, hand-crafted wooden steering wheels.

[bigjohn331958@gmail.com](mailto:bigjohn331958@gmail.com)

**THANK YOU TENNESSEE T'S  
THANKS FOR THE PICTURES  
AND ARTICLES THAT YOU  
SUBMITTED THIS MONTH. I  
CAN'T TELL YOU HOW MUCH IT  
HELPS ME WHEN YOU  
WRITE THE NEWSLETTER.**

*Bill Robinson,  
newsletter  
editor*

If you have not found the **TECH PAGE** on our website, then pay it a visit. There are many good articles posted that can help out on your next project. Also, if you write an article, send it to the newsletter editor for consideration.

**Membership Application click here**