



Editor- [Paul Gierow](#) with assistance of
[Bill Robinson](#)

Be sure to visit our club's website

<http://tennesseets.weebly.com/>



Greetings Model T'ers

Hope you are all making it well with this cold weather we are having. It's been rough the last few days. With the snow and ice and zero temperatures I have been hanging out watching a lot of Gunsmoke. Vandy is on a cruise where it is 80 degrees, me and the dog are doing the best we can. Of course Ollie, our Saint Bernard loves this cold. She played all yesterday afternoon with the neighbor kids.

Speaking of Gunsmoke, my first thought is what if Matt had a Model T to get around in. They are always talking about going on a trip with their horse and averaging about 20 miles a day. A lot of people back in the day never went more than a few miles away from home. They married someone close by because they had to. Just think of how lives were changed with the introduction of trains and then the automobile, especially the Model T which were made affordable for the masses. I often think of how much the Model T changed the world.

Over the past few days, I have been eating snow cream, fixing frozen water pipes and trying to keep other pipes from freezing. I have been checking on my cars and thinking of warmer weather. It's been close to a month now since I have been for a ride. Like most of you I am looking out my window, watching it snow, and thinking of the new parts that are being shipped, and making plans for the cars and the upcoming car shows and tours.

I will be getting back to you soon with tour information.

In the next few weeks, stay warm, get your cars ready when you can and let's go touring this spring.

Happy T'ing
Ricky

Club Officers

President- Ricky Williams
Humboldt, TN
731.618.0207
rwilliams@humboldtministorage.com



Vice President- Dennis Plank
Humboldt, TN
731.616.6609
daplank@bellsouth.net



Secretary- Vandy Williams
Humboldt, TN
731.414.9085
vandy1311@yahoo.com



Treasurer- Connie Plank
Humboldt, TN
731.313.1496
csplank@bellsouth.net



Chaplain- Don Demio
From Tennessee



Tours and Events

Contact Ricky Williams, our club President, if you have a tour or event planned to be sure the date is still open.

Date	Event (Tennessee T's events are bold)
➔	Note: contact the event host before making plans to attend.
March 2, 2024	Winter Swap Meet Country Roads, T&A Marietta, OH
Spring 2024-TBD	Lynn Cook Day somewhere in TN?
59th MTFCA Annual Meeting	Oklahoma City, OK March 21-23, 2024
Spring 2024 Sometime ?	Nobody will Commit Tour, near Stella TN
Homecoming at the Model T Museum	Richmond, Indiana June 1, 2024

INDEX	
President's Page	pg 1
Officers & Tours & Events	pg 2
Chaplain's Report & Treasurer's Report	pg 3
Trivia question	pg 3
Paula's Tour Summary	pg 4
Moonshine Mike	pg 12
Planning a Tour-Bill Robinson	pg 15
Herms fix it	pg 18
Trivia Answer	pg 19
New Member Application	pg 21



The Tennessee T's club is a member of both the MTFCA and the MTFCI. Most of our members are also members of both associations that help preserve our hobby and our historic old cars.

Chaplain's Report: January 2024

By Don Demio, Tennessee T's



There were Get Well cards sent on 11/14 to Ramona Akin after the back surgery and on 11/16 and on 1/4 to Bill Robinson after medical tests and a hospital stay.

Should you experience or become aware of one of our members experiencing a death in the family, hospitalization or serious medical issue, please inform one of our club officers if you wish us to support you.

Jeremiah 29:11 (KJV)

For I know the thoughts that I think towards you, saith the Lord, thoughts of peace, and not of evil, to give you an expected end.

It is natural to be encouraged by a true leader. God is the leader we should strive to follow. If we choose to walk in his path, we will be an example other will want to follow. There is the challenge for us all.

Treasurer's Report

The Money Bucket

submitted by **Connie Plank**, Club Treasurer



Starting Balance (12/02/2023)	\$8,283.63
Total Deposits *	\$140.00
Total Expenses **	-\$178.03
Ending Balance – (01/15/2024)	\$8,245.60
* Total Deposits	
Dues	\$140.00
** Total Expenses	
Room Rental for 2023 Christmas Party	\$143.44
Sympathy Cards/Stamps	\$34.59

Model T Ford **TRIVIA**

What did Ford call this part and where does it go?



answer on pg 19

2023 FALL TOUR

November 5 - 11

by Paula Gember

Townsend, TN was the hub for the 2023 Fall Tour, hosted by George & Ramona Akin. Approximately 30 T's gathered for the event, staying either at the Talley Ho Inn or just down the road at the Riverstone Lodge.

SUNDAY, after a scenic shakedown tour, we gathered for a cookout around a cozy campfire.



Each evening, many of us sat around the fire behind the Talley Ho, swapping stories of our day's adventures.

MONDAY, we took a WINDING mountain road called the TAIL OF THE DRAGON. 11 miles and 318 turns, it's a popular ride for 250,000 bikers annually. We took our sweet time in our T's, stopping at the infamous Deals Gap close to the TN/NC state line for RR break & saw their 'Tree of Shame.'





We enjoyed a box lunch at the base of the Fontana Dam on the Tennessee River, then moseyed along the DRAGON back to hotel.



The morning air was brisk & chilly, but daily coffee stops warmed us up.



On TUESDAY, we took a morning drive through the Smoky Mountains National Park to Cade's Cove. There we toured churches and historic structures depicting life here in the 1800's.

Many of us spotted several black bears, high up in the trees, knocking walnuts down to the ground. Another bear strolled in a field behind a church.



That afternoon, we enjoyed a delicious Mexican buffet lunch at The Abbey, a beautiful old convert church.



Next, many saddled up on tour buses and headed to a dinner show at the Dolly Parton Dixie Stampede. Ye-hah!



WEDNESDAY was our free day. We got to lollygag along, visiting the shops in Wears Valley, Pigeon Forge or Gatlinburg on our own.



It was unseasonably warm & sunny as many of us hiked up Clingman's Dome and enjoyed 360 degree views from the observation tower.



Some made their way into Gatlinburg for lunch. After some shopping, we drove down congested Main Street and continued on to Pigeon Forge.



No butts about it! A few had fun at "Goats on the Roof" in Pigeon Forge, even riding on their 'Goat Coaster.'

On THURSDAY, our day began with a beautiful & cloudy sunrise followed by breakfast at the Pancake House.



We gathered at the home of local Jerry Hodge to see his impressive antique car collection and a garage full of automotive memorabilia.





That afternoon, we had a manifold cooker chili lunch at the Tennessee State Historic Park Fort Loudoun. We toured the reconstructed fort built by the British in the 1700s during the French & Indian War.

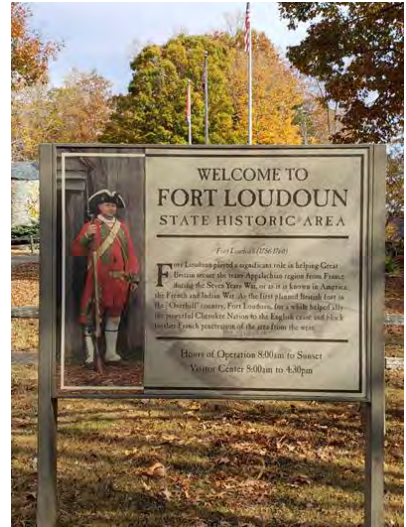

FRIDAY, we stopped at Blowing Cave Mill and had lunch at the Bush Bean Restaurant, across the road from their plant in Chestnut Hill. We visited the Bush museum and gift shop.

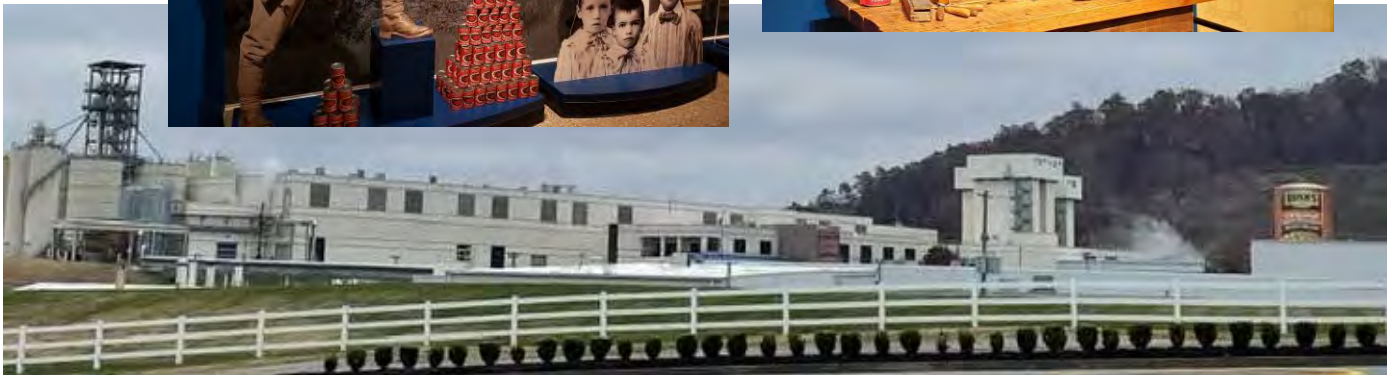

The evening ended with a closing banquet at Miss Lilly's in Townsend. George & Ramona said this was their last tour as hosts, and have turned the reins over to Milt & Rosemary. We gave the Akins a thank you gift for their years of exceptional tours, signed on the back by all of us.



Moonshine Mike Upgrades his T

by Phillip Lee

The hunting trip had been decided with the permission of Ma. Still it would be a few weeks before the trip and Moonshine Mike needed to get some cash for the hunting supplies, so off to the still to load up for a trip to Turtle Dip Roadhouse. On his way to the still, who do you think Moonshine Mike came across? None other than the “high” sheriff, Raymond Josia. Sheriff Josia was driving a brand spanking new Ford Model T Fordor car. They stopped driver side door to driver side door. Moonshine Mike said, “Good morning Ray, see you gotcha a new car. When did that happen?” “Oh, picked it up one day last week and just taking it out for a ride. Where you headed, Mike?” replied Sheriff Josia. “Now, Sheriff, you know it aint none of yo business long as I aint doing nothing wrong, and you aint seen me doing nothing wrong.” Sheriff Josia said, “Well, you be careful riding in these hills and tell May Belle I said howdy.” Moonshine Mike replied, “Will do, you be careful with that new “T” of yours.” They both gave a little wave and drove off.

Moonshine Mike stopped around the next curve to see if the high sheriff turned around to try to follow him, but after sitting for a few minutes the sheriff did not show up. As a matter of fact, the sheriff had stopped around the corner and walked back through the woods and watched Moonshine Mike sit in his “T” for a few minutes and then drive off. Sheriff Josia watched Moonshine Mike drive off, then to himself said “One day “Moonshine Mike” I will catch you with your shine and haul your tail off to jail.” The sheriff walked back to his new “T” and drove off back toward town.



After deciding that the sheriff was leaving him alone, Moonshine Mike took his time getting near the still and after sitting there for about half an hour or so, he loaded some “shine” in his truck and headed over the ridge to Turtle Dip Roadhouse. As he was unloading the “shine” he said to Big Sam, “I crossed paths with the sheriff before getting to my still. He has got his self a brand new car. I wonder if this old “T” of mine can still out run the sheriff in his new “T”.” Big Sam responded, “I heard that he got one of them things called “Rucks tell” or something like that and that means he can climb the hills round here faster than you can in your truck.” Moonshine Mike asked, “Do you know what I can do to make my “T” faster than his?” Big Sam said, “I heard some talk about something call a “Muncie Transmission” but I don’t know nothing about it. You should talk to Trader Jim, he can tell you all about it.” As he started walking toward the front of his truck, Moonshine Mike said, “Thanks Sam, after I drop some of this money off with Ma, I think I will go see Trader Jim.”



When Moonshine Mike got back home late that afternoon he gave some of the money to Ma to put under the floor board in their bedroom. Ma said, “Mike, looks like you got something on your mind. What is it?” Moonshine Mike replied, “Saw the sheriff today and he has done got himself a new sheriff car. Don’t think I can out run him now. Big Sam said that I needed to see Trader Jim about making my ole “T” run faster. Oh, he said to tell you “Howdy”. I’ll be going to see Trader Jim come daylight tomorrow.”

After a sleepless night, Moonshine Mike was sitting at the table when Ma got up to start breakfast for Moonshine Mike and the kids. Moonshine Mike had started the fire in the cookstove so it was ready when Ma got the biscuits fixed. Ma put a big slice of ham in the pan and sat down next to Mike, put her hand on his hand and asked, “Okay Mikey, what is going on in that head of yours?” “Well, Ma, If I can’t get my ole “T” to out run Sheriff Josia, who is gonna feed you and the kids?” Moonshine Mike asked softly. Ma answered confidently, “Mikey, then you best get yourself on over to Trader Jim’s and get him to fit yo “T” so it will out run the sheriff, just like you been doing. Now soon as I get it ready you can eat a big breakfast and get going!”

After his breakfast of ham, red-eye gravy and biscuits, Moonshine Mike walked over to the “T” and started looking it over from front to rear and side to side and said to himself, (Most of us talk to ourselves when we are a wee bit troubled) “Well Mike, looks like you gotta do something to this old “T” so it will outrun that new “T” of the sheriff’s. Wonder what Trader Jim will say when I tell him that Big Sam told me about one of them Muncie transitions or something like that.” With that thought swirling around in his head, he pushed the starter button and the old “T” engine turned over but would not start. Puzzled, Moonshine Mike looked around and saw that the switch was still in the off position. He smacked himself upside his head and turned the switch and with the next push on the starter button, the old “T” sprang to life and off they went, but not far after crossing the cattle gate the “T” sputtered and stopped. “Now what?” said Moonshine Mike out loud and scratching his head. “After opening the hood and looking around he said pretty loud, “@!#\$% forgot to turn the gas on again.” After turning on the gas the “T” started right up and the rest of the trip to Trader Jim was uneventful.

As Moonshine Mike approached Trader Jim’s, he stopped in his tracks and said out loud,” That dang sheriff done got here afore me! Well that’s not gonna stop me.” When Sheriff Josia saw Moonshine Mike stop in front of Trader Jim’s he said, “Well, howdy Mike, good to see you again so soon. What ya doing out this way?” Moonshine Mike answered, “Just picking up supplies for the farm and some sewing stuff for May Belle. You here for anything special?” “Yep, I am picking up a new carburetor for my car so it will go a little faster. So, you better watch out cause I’ll be looking for you.” replied Sheriff Josia with a grin and twinkle in his eyes as he got back in his new “T” and drove away.



Moonshine Mikes continued adventures...

Moonshine Mike walked over to Trader Jim and with a little edge in his voice said, “That thing that the sheriff said he got for his car to make it go faster, what’s it?” Trader Jim replied with a little chuckle, “Oh that, it’s just a new dangled carburetor that lets more air in. Supposed to make the “T” a little faster, but I don’t know if it works or not. Sheriff is supposed to let me know after he tries it out. What can I do for you, Mike?” Moonshine Mike asked, “I was over at The Turtle Dip yesterday and Big Sam said to ask you about something called a “Muncie Transition” or something, What was he talking about?”

Trader Jim answered, “There is a new thing called a “Muncie Transmission” that will fit in your “T” and will make it so it will go up hills faster, but I don’t know about the speed. You can talk to Jack over at his blacksmith shop. He has been working on cars along with his blacksmith stuff for the past year or so. He should be able to tell you all about the Muncie.”

Moonshine Mike drove over the hill to the blacksmith shop and when he stopped in front, Jack crawled out from under an Overland and said, “ Well lookie there, if it aint Ole Moonshine Mike himself. What can I do for you, Moonshine? Did you bring a me a little sample of your shine?” Moonshine Mike said, “Sure Jack, got a quart under the feed sack in the back. Help yourself.” After taking a sip of the “shine” Jack said, “Mike, you sure make the best and smoothest sipping “shine” in this neck of the woods. Now what can I do for ya?”

“Well Jack, you probably know that the sheriff got himself a new car and I need to be sure my “T” can still outrun him. I heard about something called a “Muncie Transition”. Can you tell me about it?” asked Moonshine Mike.

“Yep, Mike, it takes a good bit to put it in your “T,” but I have already installed one so I know I can do it for you. It gives you a lower gear so that you can go up a hill faster and it gives you a higher than your high gear so you can go faster downhill or on a level road. You will need to leave your “T” with me and it will take a few days. Oh, by the way, if you don’t change gears right and get it “out of gear,” you won’t have any brakes, but I can fix that too with Rocky Mountain brakes. They make it so your brake pedal also stops your back wheels.” explained Jack.

“Okay, how much will all that stuff cost me?” asked Moonshine Mike. “Don’t know. I have to figure it out. Tell you what, Mike. We can work it out in trade for “shine” that I can sell here, that way we both come out ahead. Does that sound good to you?” asked Jack. “Sounds good to me. Just long as you make it so I can stay ahead of the sheriff. I’ll leave the “T” and walk back to Trader Jim’s. I think I can get the Indian to take me back home in his buggy for a little “shine” said Moonshine Mike, “and you can learn me to drive that new transition thing when you bring the “T” to me.” Jack replied, “Sounds good to me. See you in a few days at your place.”

It was well after dark when Running Waters got Moonshine Mike back home, got his quart of “Shine” and headed back toward his village.





How to plan a Model T ride for you and your Model T friends by Bill Robinson

If you are like me you love to drive your Model T Ford. What's best is to have your wife come along, and maybe even a friend or two join you and drive their own Model T. What I like is finding country backroads that I've never driven. It seems that when I get on one of those roads, my mind seems to shift gears, and my imagination seems to put me back in the 1910's and 20's. Suzi and I love to spot the old farm houses, cows, horses, coyotes, and deer. **The problem is.....**How do I find those old roads without going out on a Road Hunting Trip? Well, I think that I may have found a good (and fun way) to come up with a good route, while sitting at the computer (not my iPhone).

Many of you may already know about the **Ride With GPS** website, but most users haven't discovered the new addition that the programmers have added to the mapping procedure. What it does is allows the user to go to an area that he/she wants to check out, and the area may or may not be close to where you currently located- just pick out an area that you want to ride in. If you live in, or near a large city, such as Nashville, we all have figured that finding good backroads with little traffic is near impossible to find, but if you get 25 or 30 miles away from town, then you might find some good back roads. So, let's give it a try! 😊

We all know that **Leipers Fork, TN**, is a good little country town only 25 miles or so from Nashville. Not only is it very interesting, but it has good eats and great parking if you bring a trailer. **This is only an example.**

Start by opening the website <https://ridewithgps.com>. A "sign up" or "membership" is not required to create a route. Follow the directions below:

Disclaimer- My experience using RWGPS has always been on a Windows 11 type PC, and I have never needed to use a cell phone, a Mac, or any other system. I have confidence they will all work with RWGPS, but maybe not like I'm describing in this document. The links and menus may show differently.

1. Once open, Click on the link **Explore**. The map could open anywhere. To find **Leipers Fork.....**
2. ← Enter **Leipers Fork TN** in the rectangle
3. Below the choice for Leipers Fork TN routes should show up as you typed it. Click on it.

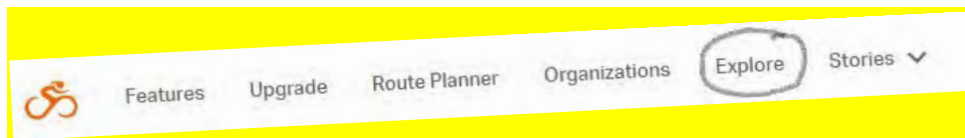

Find the menu bar- choose Explore

Once you have chosen **TN Leipers Fork 10 Mile**..... below is a section of the map that will show up. It's only a 10-mile ride, but a good one to practice on.

Tip:
cuesheets
can be
printed here
too

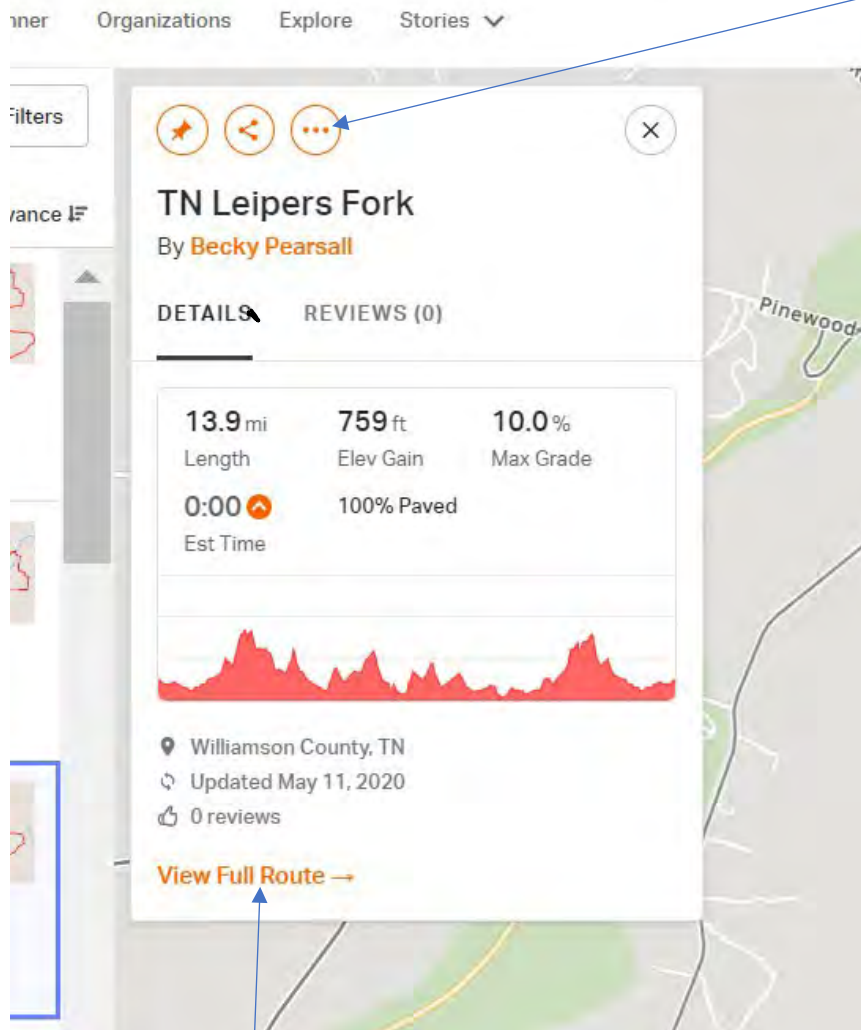

Once you click on the **TN Leipers Fork 10 Mile** route there will be the map and it will only have one map. Pasted to the map will be the image above with technical data regarding grades for bicyclists. (Hills don't concern us Model T folks!) Look for the text Stating **View Full Route** and click on it.

Scroll the **left hand column**, until you come to the **cuesheet**. Print the **cuesheet** and take a practice run.

An alternative to a practice run would be to take the tour using **Google Streetview**.

The **Google Pegman**  in the right hand corner of the map will allow you to sample the roads that are included in the route. By using the Streetview, you have the opportunity to virtually ride the routes from home, plus you have a chance to try a different route, or combine routes. When you decide that it's time to ride the routes in real-time, you may come to a section of the road that stirs your interest as a "side-road", so ride it out and see where it goes. Document the changes on the cuesheet and keep driving.

Once done, click on the link **Route Planner**, follow the directions that appear, use your **cuesheet** and create your own route. Once you get the hang of things, you'll be able to copy a route, join routes, or simply create a route from scratch. Create a route, then print your **cuesheet** and share it with your **Model T partners**.

Maybe after a trip or two have been planned and run, we hope that you may be interested in planning a one-day or two-day ride, or even a tour for the Tennessee T's. Just check with our club President for date availability.



FORD FIX AND FACTS

Herm Gierow

For this month's article I have picked out a couple of aids for servicing or maintaining the Model T in proper operating condition. Both items can be easily made with a few hand tools.

Figure 1 is a simple device which is helpful in replacing the transmission bands on early cars which do not have removable transmission band ears. Instead of using string or wire to tie the bands together while replacing the transmission cover, it is much easier and quicker to use the yoke shown. A one-foot length of 1/4" diameter rod bent to the dimensions shown is all that is required. Prior to replacing the transmission cover, the ears of the three bands should be pulled together and the yoke slipped around them. After the cover is in place the yoke can be withdrawn through the access.

Figure 2 is a template of a gauge which will permit one to accurately and easily set the Model T timing. This gauge insures that the distance between the center of the commutator case spring stud and the center of the commutator pull rod is correct when the spark adjustment lever is in the fully retarded position. In use, the gauge should be placed over the spring stud and the commutator pull rod bent in such a manner that it will align with the remaining hole in the gauge. If the rod does not align when the spark lever is fully retarded you have an incorrectly timed engine. To make the gauge accurate I suggest that your material be bent to obtain the desired offset prior to cutting and drilling the final hole. The gauge shown was one approved by Ford for use in making this timing adjustment and was made by K. R. Wilson.

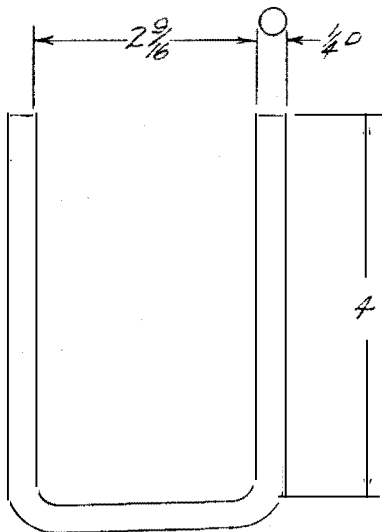

FIG. 1

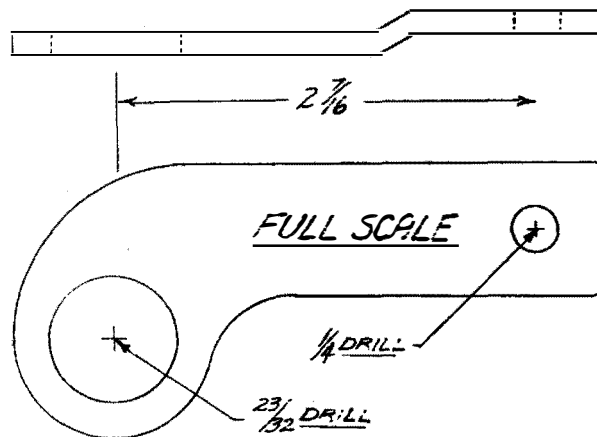

FIG. 2

Editors Note: My Dad began restoring my Model T in the early 1960's. The following is from the July 1967 Auto Antiquarian News. Note : that the timer tool will not work with Anderson timers.

TRIVIA answer



Answer to Trivia:

Thimble helps hold the radiator.

source: Thanks to Phillip Lee (aka moonshine mike) for inputs



Make sure you get a baby carrier for the Grand Babies!!

PROTECT YOUR CAR
against theft

Locks may be picked or jimmed. Cars may be stolen in spite of them

BUT NO THIEF EVER ATTEMPTED TO STEAL A CAR WITH A MAN AT THE WHEEL

Bosco COLLAPSIBLE RUBBER DRIVER

is so lifelike and terrifying, that nobody a foot away can tell it isn't a real, live man.

When not in use, this marvellous device is simply deflated and put under the seat. Easily inflated with your hand, or automatic pump. Price \$15.

Order through your dealer or direct from
BOSCO, Inc., Akron, Ohio

An old advertisement source: from Floyd Clymer Model T restoration handbook

HAY!!
 Let's get these wheels 'a'rollin!
 Plan a tour!

Hey, we tour the whole dang state!
 And then some!
 Don't tell anyone, but sometimes we even cross over the state line. Shhhh !!

FULL TIME COLLEGE STUDENTS CAN JOIN DUES - FREE

BOOGER... IN THE PAN!

Find something in your old car that is not supposed to be there? Let us all see your find!

Here's how:
 Write a short article and tell our club members about what you found. Send pictures to the editor. pgierow@tennrose.com

If you have not found the **TECH PAGE** on our website, then pay it a visit. There are many good articles posted that can help out on your next project. Also, if you write an article, send it to the newsletter editor for consideration.

FACEBOOK

For those members who don't already know it, the Tennessee T's club now has a Facebook page that is hosted by Ricky and Vandy Williams. To find it click on the link **FACEBOOK** - Where it says "search Facebook" type in Tennessee T's.

Please leave comments, videos, pictures, etc to let Rick and Vandy know that their efforts aren't wasted

MEMBERSHIP APPLICATION

for
TENNESSEE T'S, INC.
Model T Ford Club

Name _____ Spouse _____

Birthday _____ Birthday _____

Anniversary _____

Email _____ Email _____

Cell Phone _____ Cell Phone _____

Address _____

City _____ State _____ Zip _____

Home Phone _____

ANNUAL MEMBERSHIP DUES: .. \$20.00
Due By: *January 1st / each year*
Make Check Payable To: **Tennessee T's, Inc.**
Mail To: *Vandy Williams, Secretary*
97 Creekwood Rd
Humboldt, TN 38343
731-414-9085

You are cordially invited to join the Tennessee T's, Inc. pursuant to the rules and By-laws governing the club and its membership. You must be a member in good standing of either the Model T Ford Club of America or the Model T Ford Club International. (WE ENCOURAGE MEMBERSHIP IN BOTH.) To participate in chapter events (tours), your vehicle must meet chapter safety guidelines. *(Safety form is not required for club membership.)*

MTFCI# _____ **MTFCA#** _____

List cars (body style and year)

- | | |
|----------|----------|
| 1. _____ | 4. _____ |
| 2. _____ | 5. _____ |
| 3. _____ | 6. _____ |

Signature

Date